

LGMG ELECTRIC STACKER



SPECIFICATIONS

MODELS		CDDB12 3600
Drive	/	Battery
Type of operation	/	Pedestrian
Load Capacity/rated load	Q(t)	1.2
Load centre distance	c(mm)	600
Load distance, centre of drive axle to fork	x(mm)	710
Wheelbase	y(mm)	1097
Weight		
Service weight	kg	620
Axle loading, laden front/rear	kg	520/1300
Axle loading, unladen front/rear	kg	440/180
Tyres / Chassis		
Tires	/	Polyurethane
Tire size, front	x w(mm)	Φ210×75
Tire size, rear	x w(mm)	Φ84×93
Additional wheels(dimensions)	x w(mm)	Φ100×50
Wheels, number front/rear(x=driven wheels)	/	1x + 1/2
Tread, front	b10(mm)	550
Tread, rear	b11(mm)	400/515
Dimensions		
Lowered mast height	h1(mm)	1930
Free Lift height	h2(mm)	1514
Lift height	h3(mm)	1514
Extended mast height	h4(mm)	1930
Height of tiller in drive position min./max.	h14(mm)	710/1150
Height, lowered	h13(mm)	90
Overall length	l1(mm)	1710
Length to face of forks	l2(mm)	560
Overall width	b1(mm)	800
Fork dimensions	s/e/l(mm)	60/180/1150
Distance between fork-arms	b5(mm)	570/685
Ground clearance, centre of wheelbase	m2(mm)	24
Aisle width for pallets 1000X1200 crossways	Ast(mm)	2167
Aisle width for pallets 800X1200 lengthways	Ast(mm)	2133
Turning radius	Wa(mm)	1300
Performance Data		
Travel speed, laden/unladen	km/h	4.2/4.5
Lift speed, laden/unladen	m/s	0.11/0.14
Lowering speed, laden/unladen	m/s	0.13/0.11
Max. gradeability, laden/unladen	%	5/10
Service brake	/	Electromagnetic
E-Motor		
Drive motor rating S2 60min	kW	0.65
Lift motor rating at S3 4.5%	kW	2.2
Battery	/	Lion
Battery voltage, nominal capacity K5	V / Ah	24/60
Energy consumption acc: to VDI cycle	kWh/h	0.6
Additional Data		
Type of drive control	/	DC
Sound level at driver's ear acc. to EN 12053	dB(A)	<70

Designation	Lowered mast height h1(mm)	Free lift height h2(mm)	Lift height h3(mm)	Extended mast height h4(mm)	Lift+fork height h3+h13(mm)
Single-stage mast	1930	1514	1514	1930	1600
	2330	1914	1914	2330	2000
Two-stage mast	1780	/	2514	3037	2600
	1930	/	2814	3337	2900
	2080	/	3114	3637	3200
	2280	/	3514	4037	3600

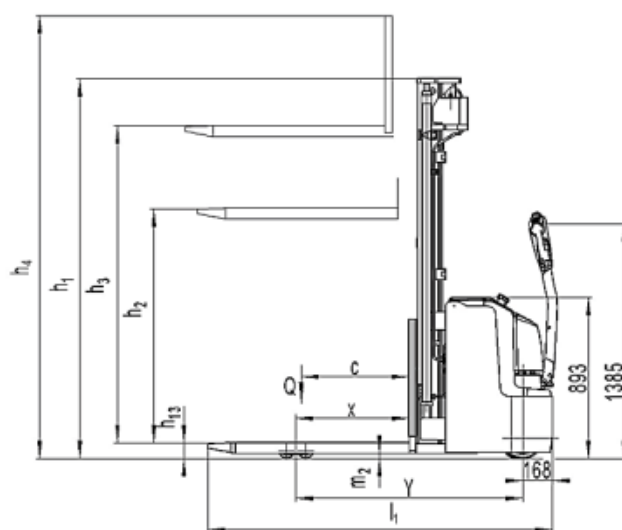
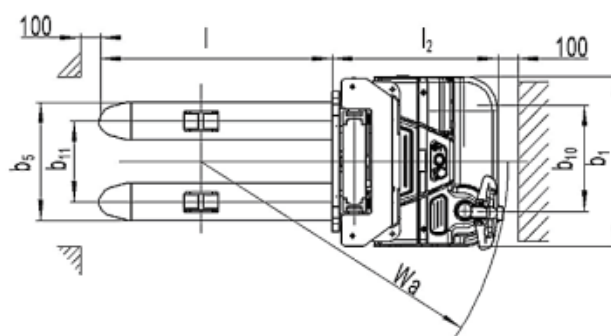

LGMG ELECTRIC STACKER



SPECIFICATIONS

Manufacturer's Type Designation		CDDB16	CDDB20
Drive	/	Battery	
Type of operation	/	Pedestrian	
Load Capacity/rated load	Q(t)	1.6	2.0
Load centre distance	c(mm)	600	
Load distance, centre of drive axle to fork	x(mm)	647	
Wheelbase	y(mm)	1293	1429
Weight			
Service weight incl.battery	kg	1340	1579
Axle loading, laden front/rear	kg	930/2010	1000/2579
Axle loading, unladen front/rear	kg	850/490	900/679
Wheels / Chassis			
Tires	/	Polyurethane(PU)	
Tire size, front	Øx w(mm)	Ø230×70	
Tire size, rear	Øx w(mm)	Ø84×70	
Additional wheels(dimensions)	Øx w(mm)	Ø150x54	
Wheels, number front/rear(x=driven wheels)	/	1x +1/4	
Tread, front	b10(mm)	522	
Tread, rear	b11(mm)	390/505	
Dimensions			
Lowered mast height	h1(mm)	1958	2078
Free Lift height	h2(mm)	/	/
Lift height	h3(mm)	2830	2830
Extended mast height	h4(mm)	3380	3500
Height of tiller in drive position min./max.	h14(mm)	850/1385	
Height, lowered	h13(mm)	90	
Overall length	l1(mm)	1964	2100
Length to face of forks	l2(mm)	814	950
Overall width	b1(mm)	820	
Fork dimensions	s/e/l(mm)	60/180/1150	
Distance between fork-arms	b5(mm)	570/685	
Ground clearance, centre of wheelbase	m2(mm)	28	23
Aisle width for pallets1000X1200 crossways	Ast(mm)	2406	2536
Aisle width for pallets800X1200 lengthways	Ast(mm)	2393	2523
Turning radius	Wa(mm)	1510	1640
Performance Data			
Travel speed, laden/unladen	km/h	5.7/6.0	5.4/6.0
Lift speed, laden/unladen	m/s	0.13/0.20	0.13/0.20
Lowering speed, laden/unladen	m/s	0.28/0.23	0.28/0.23
Max. gradeability, laden/unladen	%	6/12	6/10
Service brake	/	Electromagnetic	
E-Motor			
Drive motor rating S2 60min	kW	1.3	1.7
Lift motor rating at S3 4.5%	kW	3.2	
Battery	kg	Lion	
Battery voltage, nominal capacity K5	V/Ah	24/150	
Energy consumption acc: to VDI cycle	kWh/h	1.59	1.7
Addition Data			
Type of drive control	/	AC-Speed Control	
Sound level at driver's ear acc. to EN 12053	dB(A)	<70	

LGMG ELECTRIC STACKER



CDDB16

Designation	Lowered mast height h1(mm)	Free lift height h2(mm)	Lift height h3(mm)	Extended mast height h4(mm)
Two stage mast	1958	/	2830	3380
	2108	/	3130	3680
	2308	/	3530	4080
Two stage mast FFL (Full-Free-Lift)	1958	1410	2830	3380
	2108	1560	3130	3680
	2308	1760	3530	4080
Three stage mast	2008	/	4230	4780
	2108	/	4530	5080
Three stage mast FFL (Full-Free-Lift)	1908	1320	3930	4480
	2008	1420	4230	4780
	2108	1520	4530	5080
	2343	1756	5230	5780



CDDB20

Designation	Lowered mast height h1(mm)	Free lift height h2(mm)	Lift height h3(mm)	Extended mast height h4(mm)
Two stage mast	2078	/	2830	3500
	2228	/	3130	3800
	2428	/	3530	4200
Two stage mast FFL (Full-Free-Lift)	1978	1310	2630	3300
	2078	1410	2830	3500
	2228	1560	3130	3800
	2428	1760	3530	4200
Three stage mast	2128	/	4230	4900
	2228	/	4530	5200
Three stage mast FFL (Full-Free-Lift)	1978	1310	3930	4600
	2128	1420	4230	4900
	2228	1520	4530	5200

